

Hy-Lok FI Series

Micron Inline Filter

Catalog No. H-F200
Mar. 2004

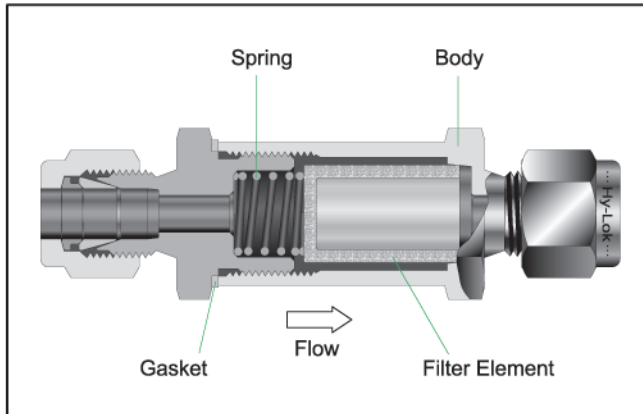

Features

- In-line filters are for use where space is limited
- Replaceable Filter element
- Particle trapping for clean fluid

Material of Construction

Description	Material / ASTM Specification	
Body	SS316 / A479	BRASS / B16
Spring	SS302	
Gasket	Silver-plated SS316 / A240	Aluminum / B209
Filter Elements	SS316 Sintered	

Flow Data at 70°F (20°C)

Nominal Element Pore Size μm	Inlet Pressure, psig (bar)			Pressure Drop, psig (bar)		
	5 (0.34)	10 (0.68)	15 (1.0)	10 (0.68)	50 (3.4)	100 (6.8)
	Air Flow, std in /min (std L/min)			Water Flow, std in /min (std L/min)		
0.5	67.13 (1.1)	103.76 (1.7)	207.49 (3.4)	1.83 (0.03)	9.15 (0.15)	27.46 (0.45)
2	341.75 (5.6)	671.30 (11)	1037.46 (17)	18.30 (0.30)	55.53 (0.91)	91.54 (1.5)
7	854.38 (14)	1525.68 (25)	2074.92 (34)	22.58 (0.37)	67.13 (1.1)	109.85 (1.8)
15	1342.59 (22)	2196.97 (36)	2563.13 (42)	27.46 (0.45)	79.34 (1.3)	128.16 (2.1)
60	2929.30 (48)	3783.67 (62)	4149.84 (68)	34.18 (0.56)	109.85 (1.8)	158.67 (2.6)
90	3112.38 (51)	3783.67 (62)	4454.97 (73)	45.77 (0.75)	109.85 (1.8)	134.26 (2.2)

Technical Data

- **Maximum Operating Pressure** : 3000 PSI @ 70°F (21°C)

- **Operating Temperature Range** :

From -20°F to 900°F (-28°C to 482°C) with SS316 body.
and up to 300°F (148°C) with Brass body

- **Effective Filtration Area** :

Series	Effective Filtration Area
FI1	0.55 sq. in. (0.00035 sq. meter)
FI2	1.30 sq. in. (0.00083 sq. meter)
FI3, FI4	2.0 sq. in. (0.00128 sq. meter)

- **Filter elements**

Elements remove 95% of particles larger than the nominal pore size.

Nominal pore Size μm	Pore Size Range μm
0.5	0.5 to 2
2	1 to 4
7	5 to 10
15	11 to 25
60	50 to 75
90	75 to 100

Operation and Filter Replacement

The filter element, which is made of sintered stainless steel, is porous and has lots of tiny holes. Particles bigger than the pores are not allowed to pass through, hence clean system media. After a certain period, the holes may be blocked by particles and pressure drop will increase. This depends upon the total flow through the elements and cleanliness of upstream flow. The element needs to be replaced for clean system media with minimal pressure drop.



HY-LOK CORPORATION

© 1998, 1999, 2000, 2002, 2003, 2004 HY-LOK CORPORATION all rights reserved

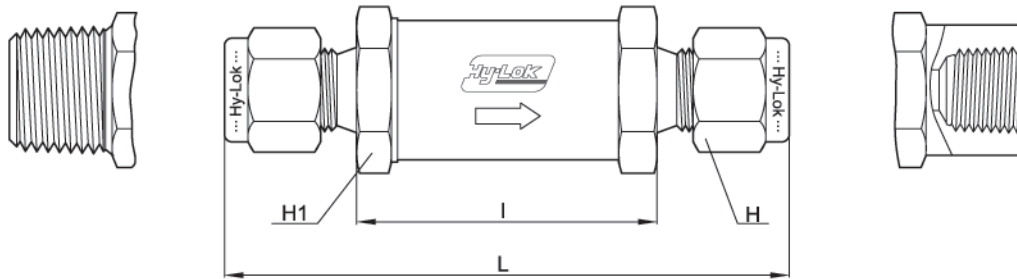

Table of Dimensions

Basic Part No.			Orifice in.(mm)	End Connection		Dimensions, in.(mm)			
Series	Part No.			Inlet	Outlet	L	I	H	H1
FI 1	H	- 2T -	0.094 (2.4)	1/8 Hy-Lok	1/8 Hy-Lok	2.35 (59.7)	1.15 (29.2)	7/16 (11.1)	9/16 (14.3)
	M	- 2N -		1/8 Male NPT	1/8 Male NPT	1.91 (48.6)		-	
	F	- 2N -		1/8 Female NPT	1/8 Female NPT	2.16 (54.9)		-	
	H	- 3M -		3mm Hy-Lok	3mm Hy-Lok	2.38 (60.5)		0.47 (12.0)	
FI 2	H	- 4T -	0.187 (4.8)	1/4 Hy-Lok	1/4 Hy-Lok	2.96 (75.2)	1.56 (39.7)	9/16 (14.3)	3/4 (19.0)
	M	- 4N -		1/4 Male NPT	1/4 Male NPT	2.69 (68.3)		-	
	F	- 4N -		1/4 Female NPT	1/4 Female NPT	2.87 (72.9)		-	
	H	- 6M -		6mm Hy-Lok	6mm Hy-Lok	2.96 (75.2)		0.55 (14.0)	
FI 3	H	- 6T -	0.281 (7.1)	3/8 Hy-Lok	3/8 Hy-Lok	3.22 (81.8)	1.70 (43.2)	11/16 (17.4)	1 (25.4)
	M	- 6N -		3/8 Male NPT	3/8 Male NPT	2.82 (71.6)		-	
	F	- 6N -		3/8 Female NPT	3/8 Female NPT	3.04 (77.2)		-	
FI 4	H	- 8T -	0.409 (10.4)	1/2 Hy-Lok	1/2 Hy-Lok	3.42 (86.9)		7/8 (22.2)	
	H	- 10M -		10mm Hy-Lok	10mm Hy-Lok	3.24 (82.2)		0.75 (19.0)	

Dimensions shown with Hy-Lok nuts in finger-tight position, where applicable.

Ordering Information

FI

Series Designator

- FI 1 : Orifice 0.094(2.4)
- FI 2 : Orifice 0.187(4.8)
- FI 3 : Orifice 0.281(7.1)
- FI 4 : Orifice 0.409(10.4)

F

End Connection Designator

- H : Hy-Lok Tube Fitting
- M : Male Pipe Thread
- F : Female Pipe Thread

4N

Size Designator

15

Fiter Element Designator

- 05 : 0.5 Micron
- 2 : 2 Micron
- 7 : 7 Micron
- 15 : 15 Micron
- 60 : 60 Micron
- 90 : 90 Micron

S316

Body Material Designator

- S316 : 316 Stainless Steel
- BRAS : brass

• NPT (ISO / BSP)

Thread (in)	1 / 8	1 / 4	3 / 8	1 / 2
Designation	2N(R)	4N(R)	6N(R)	8N(R)

• Tube O.D. Designation

Inch Tube	Tube O.D.	1 / 8	1 / 4	3 / 8	1 / 2
	Designation	2	4	6	8
Metric Tube	Tube O.D.	3mm	6mm	10mm	12mm
	Designation	3M	6M	10M	12M

■ QUALITY SYSTEM CERTIFICATES



ISO 9001
CERTIFICATE NO.GQC 212

ASME SECT III (MO)
CERTIFICATE NO. QSC 584

■ TYPE APPROVALS (for Hy-Lok Tube Fittings)



American Bureau Shipping
CERTIFICATE NO.00-BK50288-X



Lloyd's Register
CERTIFICATE NO.01/10075



GERMANISCHER LLOYD
CERTIFICATE NO.57798-91 HH



DET NORSKE VERITAS
CERTIFICATE NO.P-9100

SAFETY in VALVE SELECTION

Proper installation, material compatibility, operation and maintenance of these valves are the responsibility of the user. The total system design must be taken into consideration to insure optimal performance and safety.



Distributed by :

www.hy-lok.com

Hy-Lok FT Series

Micron Tee Filters



Catalog No. H-F100
Jun. 2003

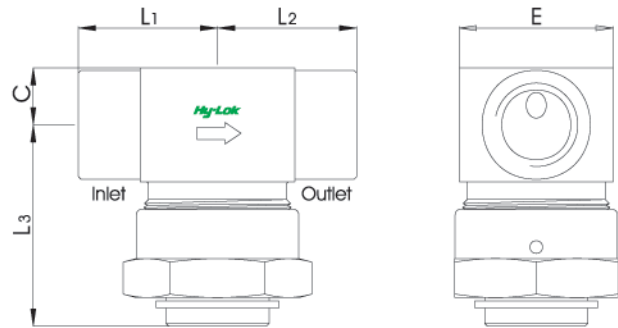
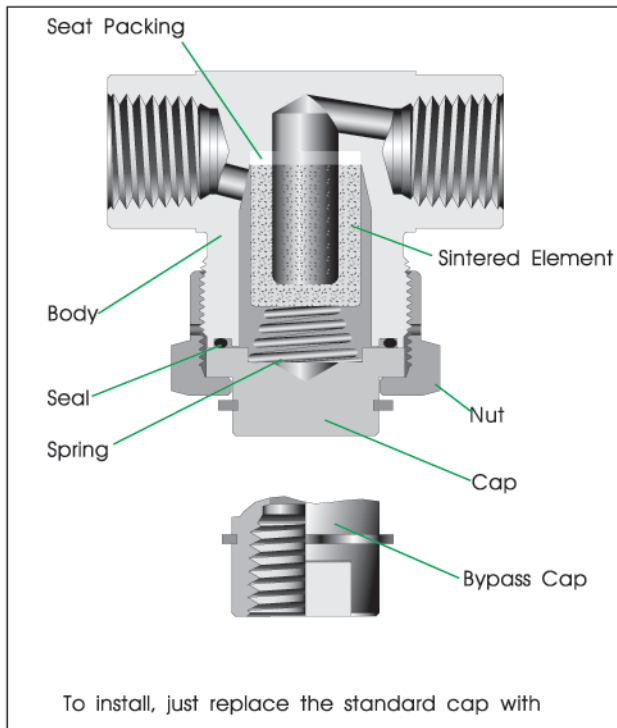

Table of Dimensions

Basic Part No.	Orifice	End Connections Inlet & Outlet	Dimensions				
			L ₁	L ₂	L ₃	C	E
FT	H -4T-	1/4" Hy-Lok	33.0	33.0	38.8	11.0	28.5
	H -6T-	3/8" Hy-Lok	36.2	36.2			
	H -8T-	1/2" Hy-Lok	38.7	38.7			
	F -2N-	1/8" Female NPT	25.0	25.0			
	M -4N-	1/4" Male NPT	25.5	25.5			
	F -4N-	1/4" Female NPT	27.0	27.0			
	F -6N-	3/8" Female NPT	41.0	12.7			
	F -8N-	1/2" Female NPT	31.0	31.0	44.0	15.8	31.75

All dimensions are in millimeters.

Features

- SS316 body material as standard
- Replacement of filter elements with body in line
- Compact and robust integral union bonnet design
- Particle trapping for clean fluid

Technical Data

- **Maximum Operating Pressure:**
6000 psig @ 70°F(21°C) for Stainless Steel
3000 psig @ 70°F(21°C) for Brass
- **Operating Temperature:** -60°F to 400°F (-51°C to 204°C)
- **Effective Filtration Area:**
1.73 sq. in. (0.0011 sq. meter) for all sizes.

Materials of Construction

Description	Material / ASTM Specification	
Body	SS 316 / A479	Brass / B16
Cap		
Bypass Cap		
Nut		
Sintered Element	316 Stainless Steel	
Seat Packing	PTFE	
Seal	Viton	
Spring	SS 302	

Filter Element and Cv

Element Micron Rating	Filtered Particle Size	Cv
1	1 micron	0.01
10	10 micron	0.02
50	50 micron	0.11
100	100 micron	0.30
150	150 micron	0.42

Operation and Filter Replacement

The filter element, which is made of sintered stainless steel, is porous and has lots of tiny holes. The particles bigger than the holes are not allowed to pass through, hence clean fluid. After certain period, the holes may be blocked by particles and pressure drop will increase. This depends upon the total flow through elements and cleanliness of upstream flow. The element needs to be replaced for clean fluid with minimum pressure drop.



HY-LOK CORPORATION

© 1998, 2000, 2002, 2003 HY-LOK CORPORATION All rights reserved

How to Replace the Element

1. Bleed the line to remove system pressure.
2. Unscrew the nut while holding the body steady with back-up wrench.
3. Remove the nut, cap, spring, and seal all together.
4. Remove the element out of the body and pull out the seat packing with care. It is recommended to replace the seat packing and seal at the same time.
5. Clean metal parts if necessary.
6. Insert new element into tapered bore with smooth faced tool until it seats firmly.
7. Put the seal back in place.
8. Place the spring on the cap and retighten the nut.

Bypass Cap

For sampling and purging, bypass cap is available with 1/4" female NPT threaded port.

Spares

For maintenance and changeover to bypass, the following spares are available.

Part No.	Description	Q'ty / Pack
KFT - F	Filter	1 pc
KFT - P	Seat Packing	1 pc
KFT - S	Seal	1 pc
KFT - B	Bypass Cap	1 pc

Pressure Drop vs Flow Rate of Air

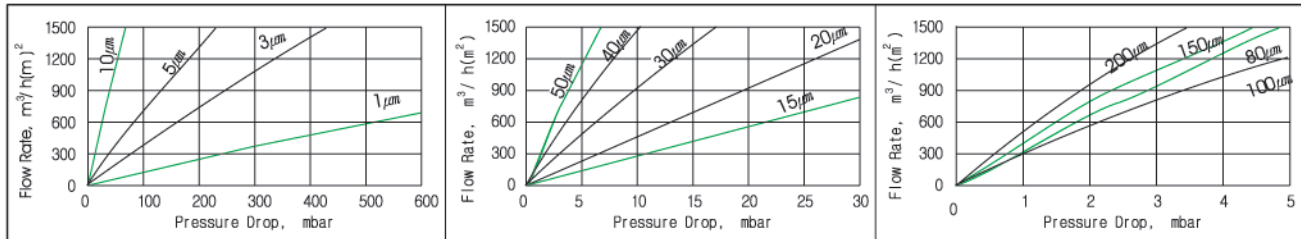

Please note the above Flow Rate is elements' co-efficient in cubic meters per hour per square meter. To get the flow rate of FT series filter, find the flow rate in the graph and then multiply it with effective filtration area on previous page.

Ordering Information

FT

Filter Type Designator

F

End Connection Designator

- M : Both End Male Pipe Thread
- F : Both End Female Pipe Thread
- H : Both End Hy-Lok Tube Fitting

B

Bypass Cap Designator*

- Nil : Without(Standard)
- B : With

4N

Size Designator

- NPT (ISO/BSP)

10

Filter Element Designator

- 1 : 1 micron
- 10 : 10 micron
- 50 : 50 micron
- 100 : 100 micron
- 150 : 150 micron

S316

Body Material Designator

- S316 : 316 Stainless Steel
- BRAS : Brass

Thread(in.)	1/8	1/4	3/8	1/2	O.D.(in)	1/4	3/8	1/2
Designator	2N(R)	4N(R)	6N(R)	8N(R)	Designator	4T	6T	8T

Note * : No designator is required for standard e.g. FTF-4N-10-S316

SAFETY in VALVE SELECTION

Proper installation, materials compatibility, operation and maintenance of these valves are the responsibility of the user. The total system design must be taken into consideration to ensure optimal performance and safety.

QUALITY SYSTEM CERTIFICATES



ISO 9001
CERTIFICATE NO.GQC 212

ASME SECT III (MO)
CERTIFICATE NO. QSC 584

TYPE APPROVALS (for Hy-Lok Tube Fittings)



American Bureau Shipping
CERTIFICATE NO.00-BK50288-X



Lloyd's Register
CERTIFICATE NO.01/10075



GERMANISCHER LLOYD
CERTIFICATE NO.57798 - 91 HH



DET NORSKE VERITAS
CERTIFICATE NO.P - 9100



Distributed by :

www.hy-lok.com